

VIISAN



VF3240 / VF3120

A3 High Speed Flatbed Scanner

User's Manual V1.7

For Windows®

Windows is a registered trademark of Microsoft Corporation
in the United States and other countries.

www.viisan.com

Precautions

Copyright:

- All rights reserved by Beijing VIISAN Technology Co., Ltd. No part of the materials shall be reproduced in any form or by any means without prior written permission.

Disclaimer:

- The screen shots in this user's manual were made with Windows 10. If you are using others Windows system, your screen will look somewhat different but functions the same.
- Specifications are subject to change without notice.
- We shall not be held liable for any damage resulting from electromagnetic interference that occurs from the use of any interface cables other than those designated by the manufacturer.

Safety Precautions:

- Do not scan originals with glue, grease, correction fluid, or wet ink on it which can cause malfunctions.
- When moving the scanner, disconnect the power cord and connection cable.
- When doing maintenance on the scanner, remove the power plug from the outlet.
- Operate the unit on a level, well-grounded work surface, and free of excessive vibration.
- Never store the unit in hot, or very cold, or humid or dusty places.
- Don not open the unit. Risk of electric shock.
- Never spill liquid of any kinds on the scanner during operation. Also do not touch the power adapter with wet hands.
- For an extended storage period, we recommend storing the unit in a cool and dry place.
- If the scanner is left in extreme cold or hot conditions, allow it to adjust to normal room temperatures before use.
- Only use accessories specified by the manufacturer.
- When left unused for a long period of time, remove the power plug from the outlet.
- Always handle the unit with care. Avoid dropping and strong impact.
- Do not leave the Scanner within the reach of children.



Environmental Information:

- Discarded electrical and electronic appliances are recyclable and should separate from the household waste. Please actively support in conserving resources and protecting the environment by returning this appliance to the collection centers.

Contents

Precautions	2	Launching Event Utility	24
Copyright	2	Power Saving	24
Disclaimer	2	Configuring the Scan To Functions	25
Safety Precautions	2	Adjusting the Setting Tabs	26
Environmental Information	2	The Destination Tab	26
Package Contents	4	Scan to Folder	27
Scanner Parts	5	Scan to PDF	27
System Requirements	6	Scan to E-Mail	28
Driver and Applications	6	Scan to Print	28
Installation	7	Scan to OCR	28
Installing the software	7	Scan to Application	28
Connecting the Scanner	8	The Scan Settings Tab	29
Placing the Originals	9	Adjustments	31
Scanning Using ViiScan	10	Image Processing Settings	32
About the ViiScan	10	The Page Settings Tab	34
Launching ViiScan	10	Reset to Default	35
About the ViiScan interface	11	Exit Event Utility	35
Adjusting the Setting Tabs of ViiScan	11	Preferences	35
The Scan Settings Tab	11	Enable Direct Scan	36
The Image Processing Tab	15	Maintenance	37
Preview Window Controls	19	Cleaning the Flatbed Glass	37
Thumbnail Window Controls	20	Specifications	38
Using Thumbnail View	20	Troubleshooting	39
Continuous Scanning	21	Scanner lights indicate an error	39
Delete the Backup Files	21	Problems starting scanning	39
Cancel a Scan	21	Scanned image problems	40
Scanning Using Event Utility	23	Scanning problems	40
About the Event Utility	23	Uninstalling and installing driver or applications	41
Scan-to destinations	23		

Package Contents

Make sure following items are included in this package. If any items are missing or damaged, contact the dealer where you purchased the scanner.

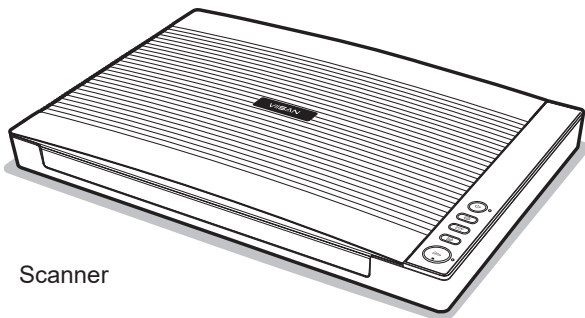

Scanner

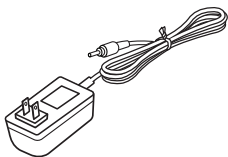

Power Adapter

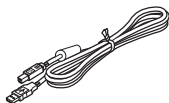

USB Cable

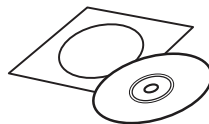

Installation DVD

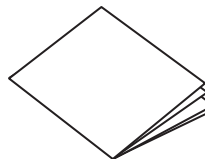

Quick Start Guide



Warranty Card

Bundled Driver and Applications:

- Scanner Driver and ViiScan Utility
- Event Utility
- OCR Engine
- User's Manual

Scanner Parts

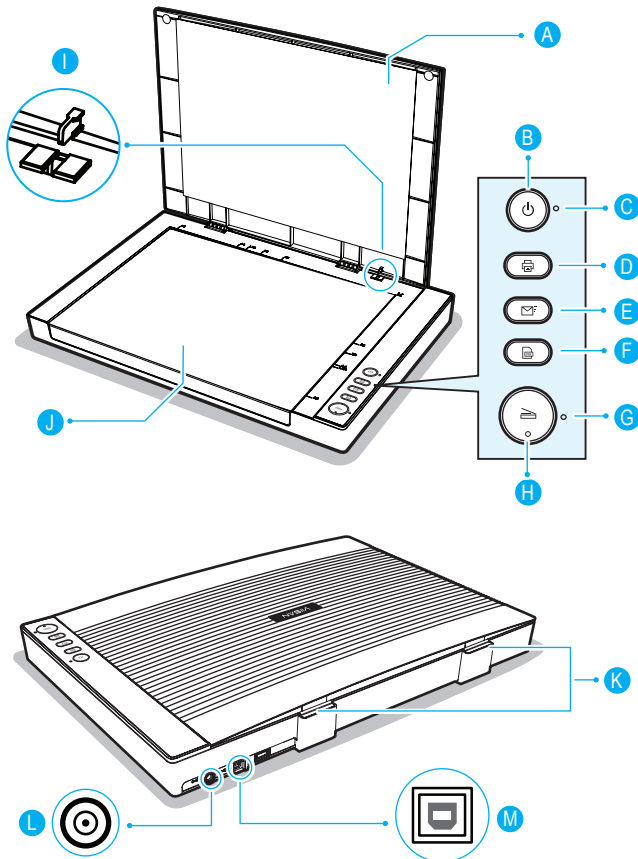

Parts	Functions
A Scanner Lid	Opens to reveal the Flatbed Glass.
B Power Button	Turns the power on or off.
C Power LED	Emits blue light when the Scanner is turn on.
D Print Button	Scan directly to your printer to make copies of a scan.
E E-Mail Button	Scan directly to E-Mail program.
F PDF Button	Scan directly to the PDF file format.
G Scan LED	Scanning : Emits green light with flashing. Disconnected : Emits red light.
H Scan Button	Scan directly to the selected folder.
I Cover Sensor	Auto scan by detecting the cover sensor. *See page 36.
J Flatbed Glass	Used to scan single pages or book pages.
K Lid Hinges	Lift the Scanner Lid straight up.
L DC IN Port	Connect the Power Adapter.
M USB Port	Connect the USB cable to a computer.

System Requirements

Following minimum system requirements are recommended to achieve the best performance from the scanner.

- Intel Core i5 Processor or Higher
- DVD-ROM
- USB 2.0 Jack
- At least 8GB RMB (Recommended 16GB)
- 2GB Available HDD Space
- Microsoft® Windows® 11、10、8.1、7

NOTE:

- The scanning software performance will be determined by the specifications of your computer. The higher specification computer will bring better performance.
- To scan at 2400x2400 DPI using a Windows PC, you need to install the 64-bit driver. This setting allows scanning of an area as large as A3 size. Note that scanning at this high resolution requires substantial memory capacity: an A3-sized scan at 2400 DPI needs at least 8GB RAM (16GB recommended for optimal performance).

Driver and Applications:

- **Scanner Driver and ViiScan Utility**
ViiScan is a driver for controlling your scanner, enabling a variety of scan settings. It also allows you to start either as a standalone application or by using other third party TWAIN-compliant application. [See page 10](#) for more details.
- **Event Utility**
This application allows to change your scanner button to other Scan To function and configured with various settings through the settings dialog, such as scanning to Folder/PDF/Email/Print, creating text OCR or opening scans with a specified application. [See page 23](#) for more details.
- **OCR Engine**
This program allows to convert the scanned file into editable text format when using the Scan To OCR (Optical Character Recognition) function of the Scanner.

Installation

Installing the software

NOTE: Do NOT connect the scanner to computer before installing the software. You must install the scanner driver first then connect the scanner to computer.

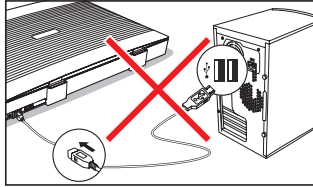

1. Insert the Installation disk into the drive of the computer then execute **[Setup.exe]** from the disk.

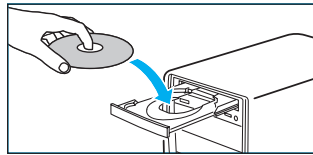

2. For Windows 11/10/8.1/7 If the **[User Account Control]** screen appears, click **[Yes]** to start installation.

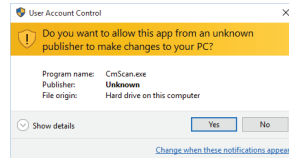

NOTE: Please install all of the applications to ensure all functions of the Scanner work properly.

3. Click **[Easy Installation]**.
If you want to reinstall only specific software that you have previously uninstalled, select **[Custom Installation]** and specify the software.

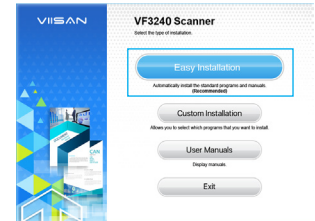

4. Click **[Install]** and follow the instructions on the screen to complete installation.



5. Click **[Finish]** to exit the program when the installation completed successfully!



Installation (Continued)

Connecting the Scanner:

NOTE: Only use the USB cable and the power adapter supplied with scanner. Use of other cables may lead to a malfunction.

1. Connect supplied Power Adapter to the scanner's DC IN port, and plug the other end to a power outlet.

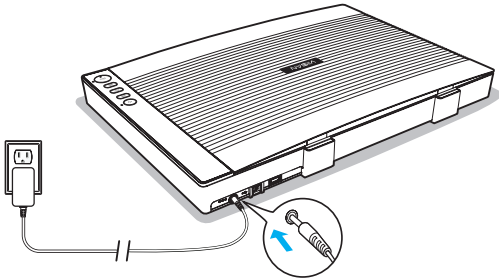

2. Connect supplied USB Cable to the scanner's USB Port and the other end to the computer.

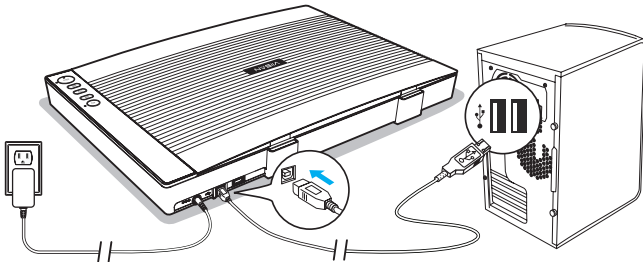

3. Press and hold **⏻ [POWER]** to turn on the scanner until the Power LED lights up in blue.

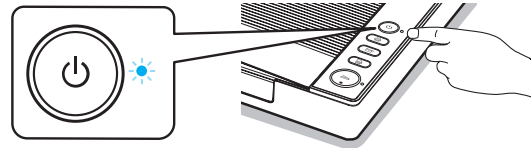

NOTE:

- To turn off the power, press and hold **⏻ [POWER]** for a while until the Power LED turns off.
- The scanner will auto power off after no operation for 15min.

4. The **[Installing Device]** window will appear when the scanner is turned on for the first time.

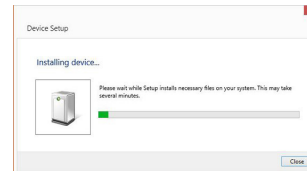

5. Please wait until the driver is finished being configured and the **[Installing Device]** window disappears.

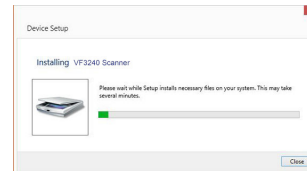

Placing the Originals

1. Open the Scanner Lid.

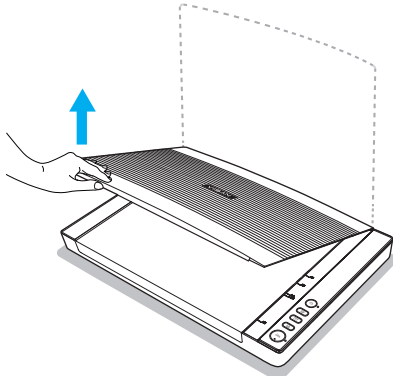

2. Place the original facing down on the Flatbed Glass, and then align the original at the position Arrow Mark.

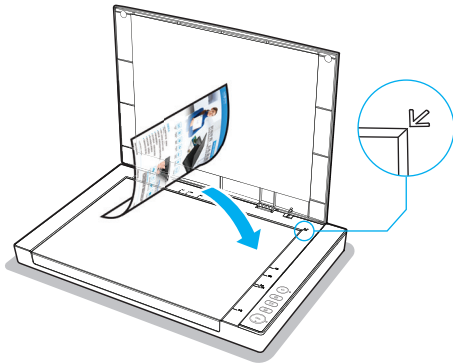

3. Close the Scanner lid gently so that your original does not move.

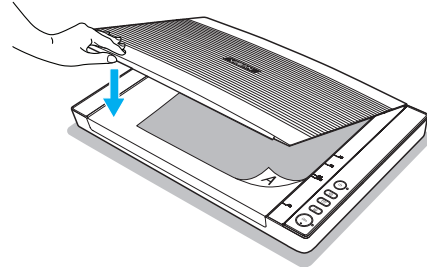

4. If you are scanning books or other thick documents, you can lift the scanner lid straight up or remove it.

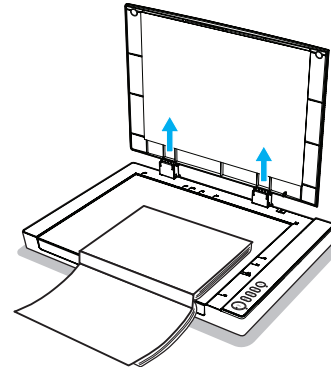



NOTE: Do not place heavy items on the Scanner Glass or press on the Scanner Glass with too much force as this will cause damage to the glass surface.

Scanning Using ViiScan

About the ViiScan

ViiScan is a driver for controlling your scanner, enabling a variety of scan settings. It also allows you to start either as a standalone application or acquire it by using 3rd-party TWAIN-compliant application like Adobe Photoshop.

Launching ViiScan

1. Click system Windows  icon then [All apps] select [ViiScan] folder to open  ViiScan program.

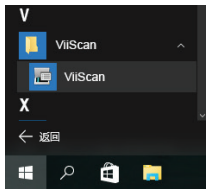

2. Select your scanner from the select source list and click [OK] then the ViiScan interface will be opened immediately.

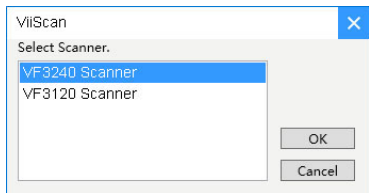

3. The ViiScan includes a preview window allowing you to preview the image before scanning the final image, you can make changes in the settings as necessary and then click [Preview] to preview the image before scanning.

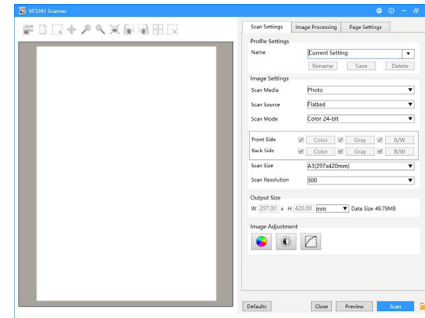

4. When the pre-scanned image appears, you can resize the scan area by dragging the marquee handles around the image to frame the desired area of the image. The area outside of the frame will be cropped after clicking the [Scan] button.

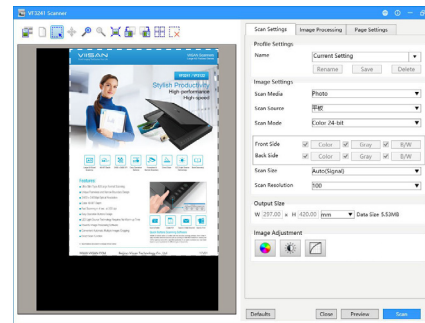

Scanning Using ViiScan (Continued)

About the ViiScan interface

The TWAIN interface is divided into two sections: the right section where most of the control settings are located, and the left section, which is the Preview Area.

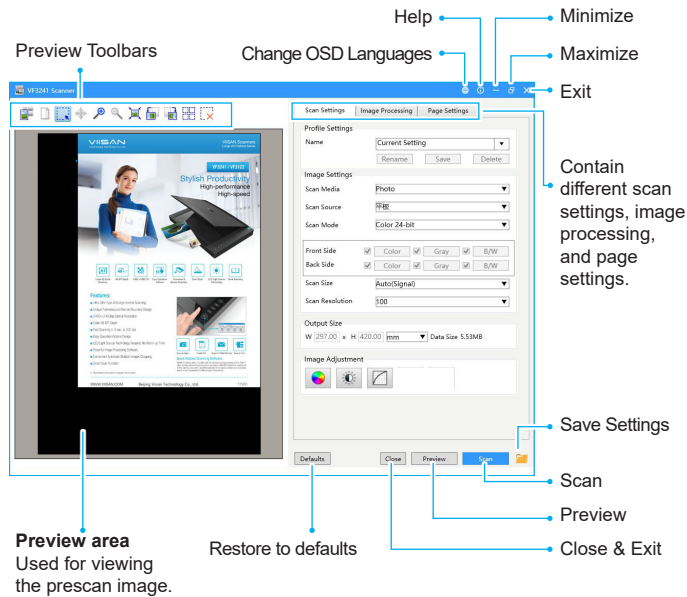

NOTE: For the detailed instructions of ViiScan dialog box, Click " ? " Help icon on the ViiScan interface to open the Help file.

Adjusting the Setting Tabs of ViiScan

There are three settings dialog in the ViiScan panel includes Scan Settings, Image Processing, and Page Settings tabs. The following are the function descriptions and examples of the available settings.

The Scan Settings Tab

Click the Scan Settings tab to bring up the setting page. You can make change as following:

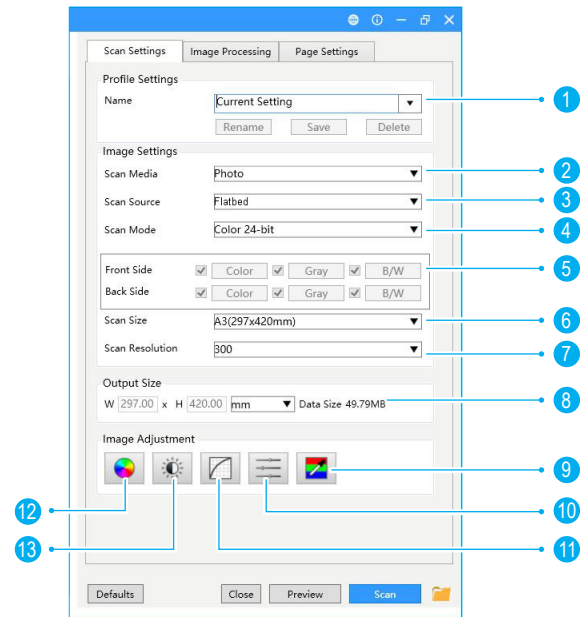

Scanning Using ViiScan (Continued)

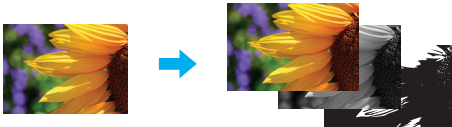
1	Favorite Settings	Create new scan profiles with your favorite settings and save them for future use.
2	Original Type	Specify an original type including "Photograph", "Text Document & Lineart", "Magazine".
3	Scan Source	The Scan Source setting is fixed as Flatbed. You cannot change this setting. NOTE: The Scan Source may vary depending on your scanner type.
4	Scan Mode	Specify a mode to scan your originals including "Color", "Gray", "B/W", "Multi-Color Output".
5	Multi-Color Output	<p>Tick the checkbox to select the modes including: "Color", "Gray", "B/W". You can make a single scan to be saved up to 3 separate images simultaneously.</p>  <p>You can press the "Color", "Gray", or "B/W" button to set different settings for each mode.</p> <p><input checked="" type="checkbox"/> Color <input checked="" type="checkbox"/> Gray <input checked="" type="checkbox"/> B/W</p>
6	Scan Size	<p>Specify a paper size including:</p> <ul style="list-style-type: none"> Flexible A3 (297 x 420mm) A4 (210 x 297mm) B5 (148 x 210mm) A6 (105 x 148mm) B6 (128 x 182mm) Letter (216 x 297mm) Legal (216 x 356mm)

7	Scan Resolution	<p>Select the resolution of the image to be scanned with following choices: "100dpi", "200dpi", "300dpi", "600dpi", "1200dpi", "2400dpi".</p> <p>NOTE: The change of Scan Resolution will apply to the selected cropping frame only.</p>
8	Output Size	<p>Display the width and height of the cropping frame. You can adjust the output size by dragging the edges or corners of the cropping frame in the Preview Window.</p>
9	Color Dropout	<p>This setting removes a single color (Red, Green or Blue) such as marks, stamps and retains the black text. If "None" is selected, No color is dropped out. Example of removing the red stamp:</p>  <p>You can adjust the Filter Threshold slider when the color selected cannot drop out. Drag the slider toward "Maximum" to remove more selected color, and toward "Minimum" to keep more selected color in.</p> <p>NOTE: Color Dropout can only be specified in "Gray" and "B/W" mode.</p>

Scanning Using ViiScan (Continued)

9

B/W Threshold Settings



NOTE: This function is only available when scanning in B/W, or Multi-color Output (B/W) mode. You can convert the scanned image in black and white using following method:

Auto Threshold: It finds an adequate threshold value automatically to obtain a clear image and remove dark backgrounds from the image.



Manual Threshold: You may manually adjust the Filter Threshold value (-100 ~ 100) until you are satisfied with the result.

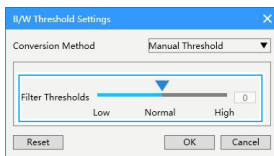

Halftone Pattern: This provides 3 halftone patterns, each creates a halftone effect using a pattern of black and white dots that can represent darker or lighter color values. You can slide the Filter Threshold value (-100~100) if you want to increase or decrease the edge weight of patterns.

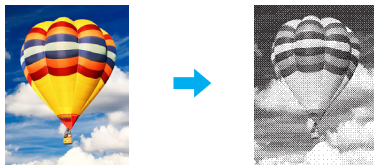

10

Tone Curve Settings



In this settings you can adjust the color tone of an image by selecting the channel of color. You can Adjust the R.G.B channels as combined or adjust specified channel.

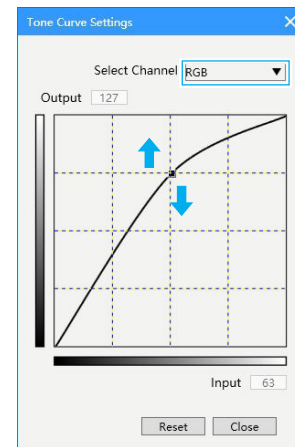

Channel Options:

RGB: Adjust the Red, Green, and Blue combined.

Red: Adjust the Red channel.

Green: Adjust the Green channel.

Blue: Adjust the Blue channel.

NOTE:

- Only Gray will be displayed in Channel when Color Mode is selected Gray.
- This function is disabled in B/W mode.

Scanning Using ViiScan (Continued)

Brightness/
Contrast/
Shadows/
Highlight
Settings

10



NOTE: This function is disabled in B/W mode.

Brightness:

Move the slider to increase or decrease the value (-100 ~ 100) to adjust the image brighter or darker.



Contrast:

Move the slider to increase or decrease the value (-100 ~ 100) to adjust the contrast higher or lower.



Shadows:

Move the slider to adjust the value (0~100%) to bring out the detail in harsh shadow areas.



Highlights:

Move the slider to adjust the value (0~100%) to bring out the midtones.

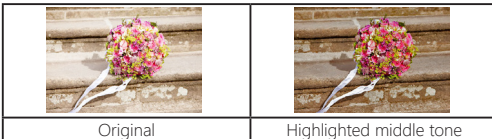

11

Color
Adjustment



Hue :

Move the slider to increase or decrease the value (-100 ~ 100) to adjust the Hue.

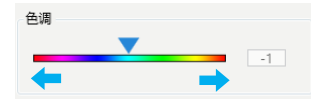

Saturation :

Move the slider to increase or decrease the value (-100 ~ 100) to adjust the saturation.



Color Balance:

You can adjust the tint when photos are tinted with red and green due to the weather or the lighting where the photo was shot.

- Cyan & Red
- Magenta & Green
- Yellow & Blue

Below is an example of an image in which the "Cyan & Red" pair has been adjusted.



NOTE: This function is enabled in Color mode only.



Scanning Using ViiScan (Continued)

The Image Processing Tab

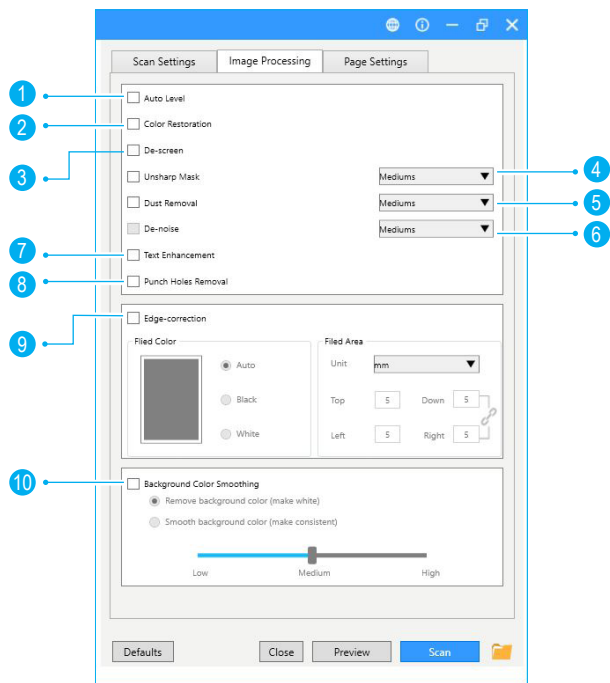



You can use the features on the Image Processing tab to scan your originals in ViiScan. The following table gives examples and descriptions of the Image Processing settings.

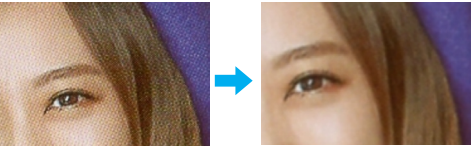

NOTE: Some items may not be available depending on scan settings you made.

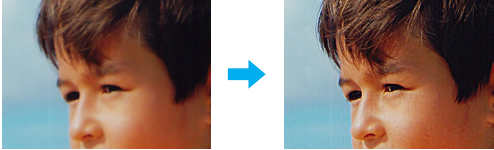
<p>1</p>	<p>Auto Level</p>	<p>Auto Level helps automatically adjust both the color and contrast of scanned image, based on the shadows, midtones, and highlights that it finds.</p> <p>Original Auto Level Applied</p> 
<p>2</p>	<p>Color Restoration</p>	<p>Color Restoration helps to restore the lost color in old pictures and makes them to their original colors.</p> <p>Original Color Restoration Applied</p> 
<p>3</p>	<p>Descreening</p>	<p>Descreening helps to reduce moire patterns in magazines or other printed materials. After descreening, the image may appear blurry.</p> <p>Original Descreening Applied</p> 

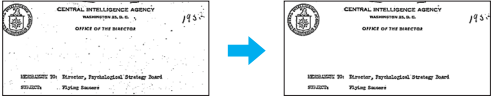
Scanning Using ViiScan (Continued)

5	Unsharp Mask	<p>This function helps to emphasize edges in the image more clearly for an overall sharper image.</p> 
6	Dust Removal	<p>The dust removal function can remove dusts or scratch marks without affecting the image composition.</p> 
7	De-noise	<p>De-noise helps to remove small dots or specks appear in the background of scanned document.</p> <p>NOTE: De-noise is enabled in "B/W" mode only.</p> 
8	Text Enhancement	<p>This function enhances the contrast between the texts and the background for readability.</p> 

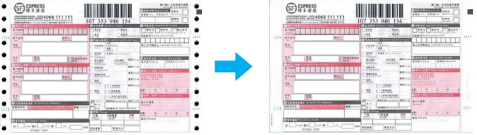
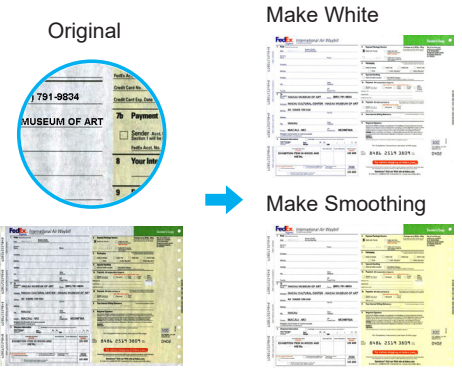
9	Punch Holes Removal	<p>This function can remove the round-shaped punch holes around the edges of the documents. The punch holes around the edges are replaced with the color closest to the document.</p> <p>Original Punch Holes Removal Applied</p>  <p>NOTE:</p> <ul style="list-style-type: none"> Punch holes will not be removed if the documents are placed skewed and without cropping. The shape of punch holes that is not round can not be removed. Punch holes may not be removed if the holes overlap the text, lines or graphics.
10	Background Color Smoothing	<p>The Background Color Smoothing function allows to smooth background color or remove it and make white.</p> <p>Original Make White</p>  <p>Make Smoothing</p>

Scanning Using ViiScan (Continued)

Edge-correction Settings

(Example 1)

This function fills the missing edges with a color which matches to the image. It also adds white or black edges onto the borders of the scanned documents.

Example 1:

Automatically to fill the color of missing edges.

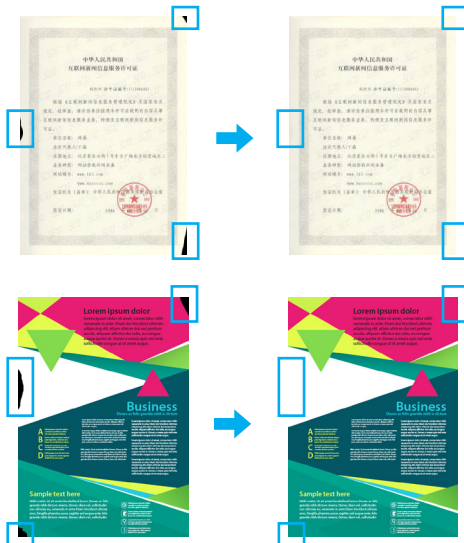
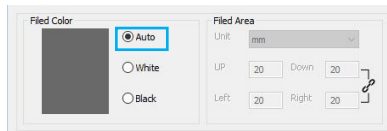

Example 2:

Add white or black edge on the border of scanned document. You can also enter a value (1~20mm).

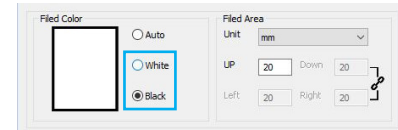

Edge-correction Settings

(Example 2)

Add white border



Add black border





Scanning Using ViiScan (Continued)

The Page Settings Tab

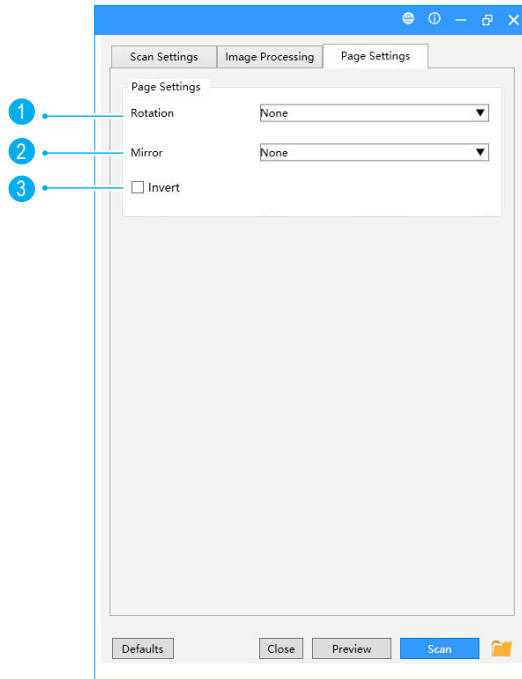
The "Page Settings" includes Rotation, Mirror, and Invert settings. You can make changes as following examples:

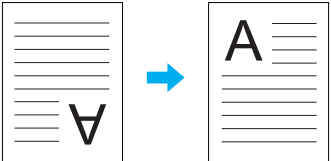
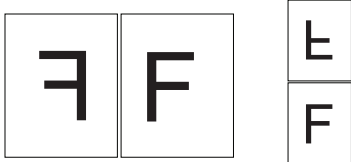



1	Rotation	<p>Select a rotation angle to rotate the image. Choices: "None", "90° CW", "90° CCW", "180°"</p> 
2	Mirror	<p>Select a mirror type for your document. Choices: "None", "Level", "Vertical"</p> 
3	Invert	<p>This function reverses the colors of the scanned image to the opposite colors.</p> 





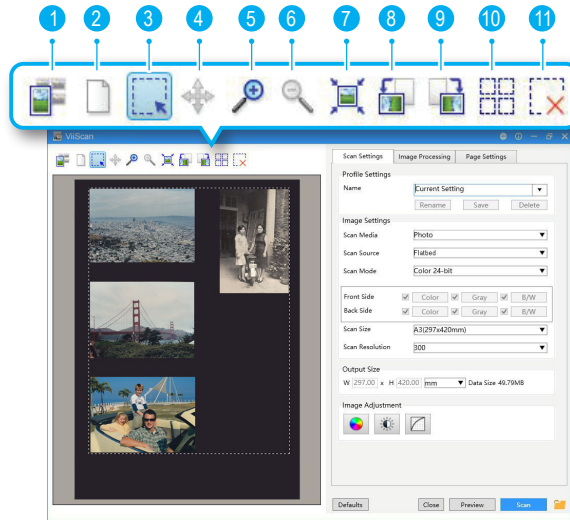





Scanning Using ViiScan (Continued)

Preview Window Controls

There are several useful tools in the Preview toolbar to assist you to check the details of the preview image.



1		Switch on/off thumbnail view *. See page 20 for more details.
2		Clears preview area

3		<p>Select scanning area</p> <p>Your can move the cursor to a corner or an edge of the crop frame (the cursor will change to ). Click and drag the cursor to enlarge or shrink the cropping frame to the desired size.</p> <p>nuts, seeds, and beans: low in saturated fat and high in protein and fiber Low-sodium canned beans (black, kidney, pinto, chick peas, cannellini) Dried lentils Unsalted nuts (almonds, pine nuts, walnuts)</p> <p>frozen vegetables and legumes: add convenience Corn Edamame Vegetable stir-fry mix (no sauce added)</p> <p>whole grains: add fiber and other nutrients to side dishes and main-dish meals Brown rice Whole-wheat couscous Quinoa</p> <p> Enlarge/shrink cursor</p>
4		Move frame
5		Zoom in (Max. 6x)
6		Zoom out
7		Fit in window
8		Rotate the image 90° counterclockwise
9		Rotate the image 90° clockwise.
10		Select all cropping frames
11		Delete selected cropping frame

Scanning Using ViiScan (Continued)

Thumbnail Window Controls

There are several useful tools in the thumbnail toolbar to assist you to check or uncheck the thumbnail.

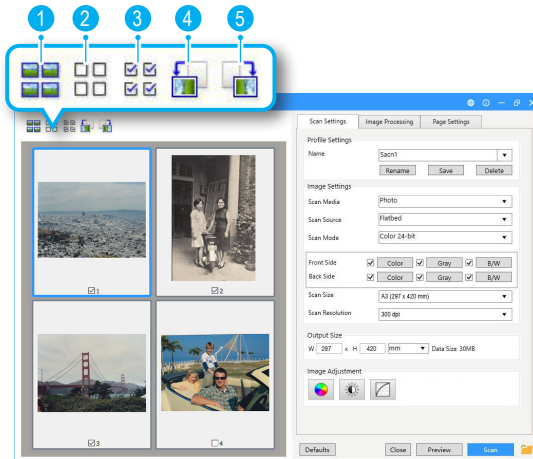

1		Switch on/off thumbnail view
2		Uncheck all of the frames
3		Check all of the frames
4		Rotate the image 90° counterclockwise
5		Rotate the image 90° clockwise.

Using Thumbnail View

- Cropping frames are specified according to the originals size, and thumbnails of scanned images are displayed.
- Make sure there is a gap of at least 20 mm (0.8 inch) between the originals, when placing multiple originals on the scanner glass. Otherwise they may not preview in thumbnail correctly.

Normal View

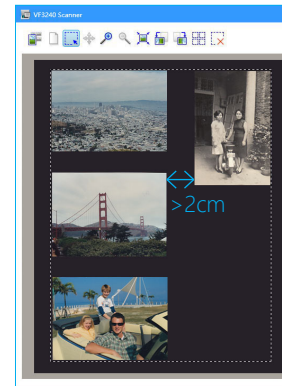

Thumbnail View



! NOTE:

- When multiple images are previewed, different outlines indicate different selection status.
- Selected "Blue outline": The displayed settings will be applied.
- Unselected "Gray outline": The settings will not be applied.
- Only the images with the checkbox selected will be scanned.

Scanning Using ViiScan (Continued)

Continuous Scanning

When “Continuous Scanning” is checked in the Setting, a dialog box appears after the previous scan finishes, asking if you want to scan the next document.

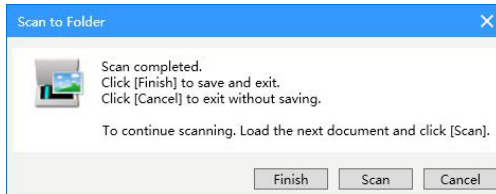

- To finish the scan. Click [Finish] to save and exit.
- To cancel the scan. Click [Cancel] to exit and without saving.
- To continuous scanning. Load the next document and click [Scan].

Delete the Backup Files

When “Delete Backup File of Scanned Image” is checked in the Settings, a dialog box appears after the scanning to Email application or printer, asking if you want to delete the scanned image.

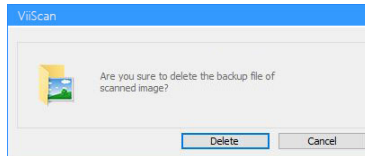

- To confirm the deletion, click [Delete].
- To keep the scanned image without deletion, click [Cancel].

Cancel a Scan

To stop the scanning process, click [Cancel] during scanning.

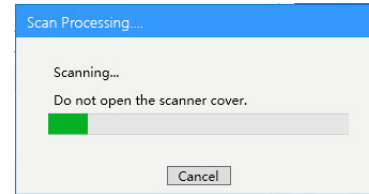

If you cancel a scan during the continuous scanning process, the following cancel dialog box appears, asking if you want to save the image already scanned before cancelling the scan.

- Click [YES] to save the file
- Click [NO] to discard the file.

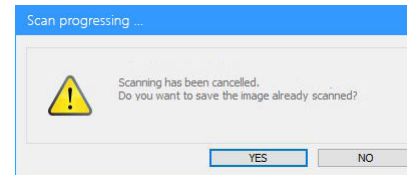

Scanning Using ViiScan (Continued)

Selecting File Save Settings

Click below folder  icon on the right bottom corner of ViiScan control panel to bring up the File Save Settings windows. You can select the scan to destination, file name, file format, and others file settings of your scan file on the File Save Settings window.

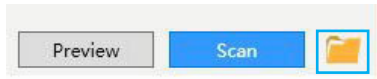

NOTE: The File Save Settings window  icon may appear when the ViiScan is be stated through TWAIN-compliant application.

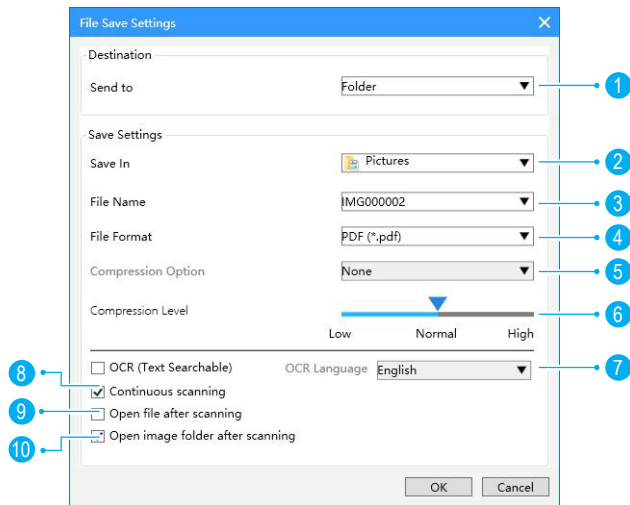

1	Send to	Select a desination for your scan file.
2	Save In	Select and edit file save path for your scan file.
3	File Name	Create a file name format for your scan file.
4	File Fomat	Select a file format to save scanned image. Choices: JPEG(*.jpg), TIFF(*.tif), TIFF Multi-page(*.tif), BMP (*.bmp), PDF(*.pdf), PDF Multi-page (*.pdf).
5	Compression Option	When TIFF file is selected in the File Format, the Compression Option is enabled with choices: "None", "LZW", "JPEG"
6	Compression Level	Use the slider to compress a file to reduce the total size in High, Medium, or Low. The higher the compression level, the lower the file size, and vice versa.
7	OCR (Text Searchable)	This setting is available with the Send To PDF and OCR options. Ensure to select the correct language of the original text from the drop-down menu to perform text recognition.
8	Continuous Scanning	Check this option to trigger the continuous scanning dialog box after the current page is scanned, allowing you to continue scanning for more pages. See page 21.
9	Open file after scanning	Check this function to open the scanned file automatically after scanning and saving completes.
10	Open image folder after scanning	Check this function to open the scanned image folder automatically after scanning and saving completes.

Scanning Using Event Utility





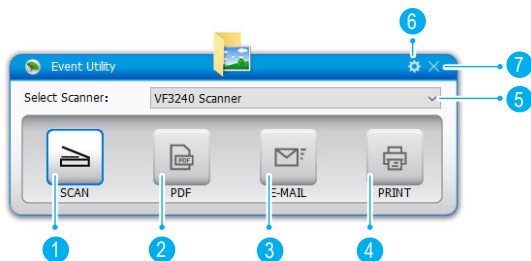

About the Event Utility

The Event Utility panel is consisted of 4 Scan To buttons which act as the respective Scanner buttons. These 4 Scan To buttons can be assigned to any of the following predefined destinations to perform one-step scanning, such as scanning to Folder/PDF/Email/Print, creating text OCR or opening scans with a specified application.





Name	Functions	
1	Scan Button	Scan directly to the selected folder.
2	PDF Button	Scan directly to the PDF file format.
3	E-Mail Button	Scan directly to E-Mail program.
4	Print Button	Scan directly to your printer to make copies of a scan.
5	Select Scanner	Drop-down menu and select your scanner.
6	Settings	Access and manage your scanner settings.
7	Hide	Hide the Event Utility panel.

Scan-to destinations

	<p>Scan to Folder</p> <p>Scan directly to a specified folder. When scanning completes, the scanned data will be saved directly into your folder on your computer.</p>
	<p>Scan to PDF</p> <p>Scan directly to PDF file format. When scanning completes, the scanned data will be saved in PDF format and opened in Acrobat Reader.</p>
	<p>Scan to E-mail</p> <p>Scan directly to your E-mail with the files saved in the specified folder. When scanning completes, your default E-mail application will open and the scanned data will be attached to a blank email.</p>
	<p>Scan to Print</p> <p>Scan directly to your printer with the files saved in the specified folder. When scanning completes, the scanned data will be printed from your default printer connected to the computer.</p>
	<p>Scan to Application (Default: MSPaint)</p> <p>Scan directly to an application (Default: MS Paint) with the files saved in the specified folder. When scanning completes, the scanned image will open in the application where you can edit it.</p>
	<p>Scan to OCR</p> <p>Scan and convert documents into editable document format, such as TEXT, Word, Excel, PDF, and open it in the word processing program or Acrobat Reader according to the File Type selection.</p>

Scanning Using Event Utility (Continued)

Launching Event Utility

Click Event Utility  icon from the system tray to bring up the Event Utility panel. Or click system Windows  icon then [All apps] to select Event Utility program.



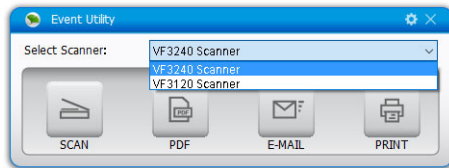

1. Click drop-down list to select your scanner and then directly press a button from the Event Utility panel to start scanning to the destination with the settings you previously configured.

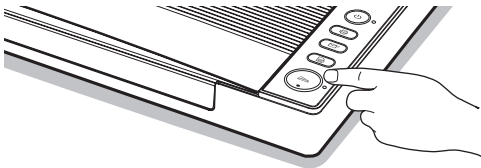

2. Alternatively, you can press a button on the Scanner to start scanning to the destination.



Power Saving

When the scanner has been no operation for 15 minutes, the scanner will automatically turn off. Event Utility  icon will appear in the system tray, indicating that the scanner is disconnected. Press the  Power button again to wake up the Event Utility panel. To turn off the power saving function, please refer to [page 35](#).

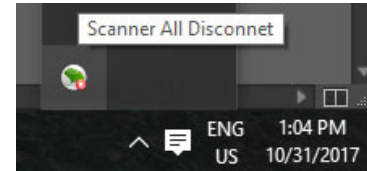

! NOTE: When the scanner is disconnected, the Event Utility will appear [**Can not connect to scanner, check again connection**] message. Make sure your cables are securely connected to the scanner and the power is turned on in order to wake up the Event Utility panel.

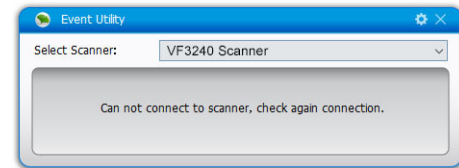

! NOTE: You must install the Event Utility from the supplied DVD-ROM in order to use the program.

Scanning Using Event Utility (Continued)

Configuring the Scan To Functions

These 4 buttons on the Event Utility panel can be changed to other Scan To functions and configured with various settings through the settings dialog. You can edit or reset to the factory default settings.

1. Click  settings icon on the right top of Event Utility panel to open the settings dialog box.

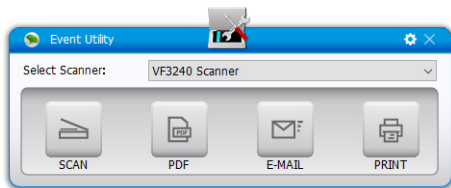

2. Select a Scan To function from the drop-down menu you want to assign to the Scan To button.

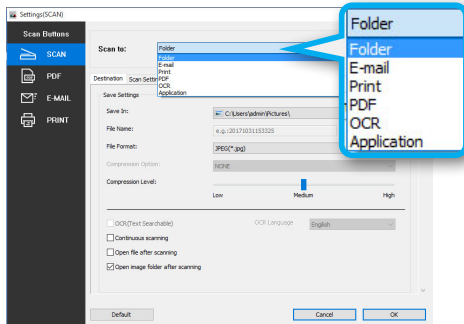

3. Click **[OK]** to set the selected scan to function with the configuration you changed and exit the settings menu.

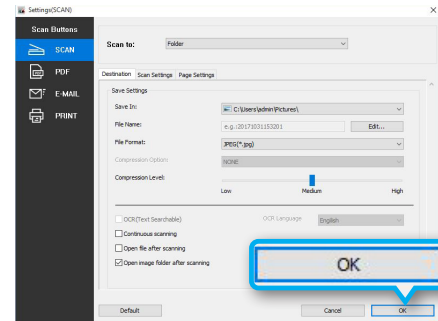

4. Click **[Cancel]** without change and exit the settings menu.

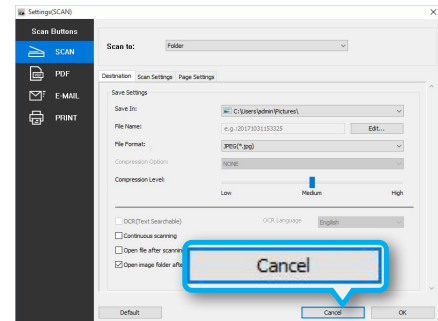

Scanning Using Event Utility (Continued)

Adjusting the Setting Tabs

The settings dialog of Event Utility includes Destination, Scan Settings, and Page Settings tabs to configure the Scan To function. The following are the function descriptions and examples of the available settings.

The Destination Tab

Click the Destination tab to bring up the setting page for the Scan-to option selected. You can make change as following:

NOTE: After changing any settings and properties, always make sure to click **[OK]** at the bottom of the menu.

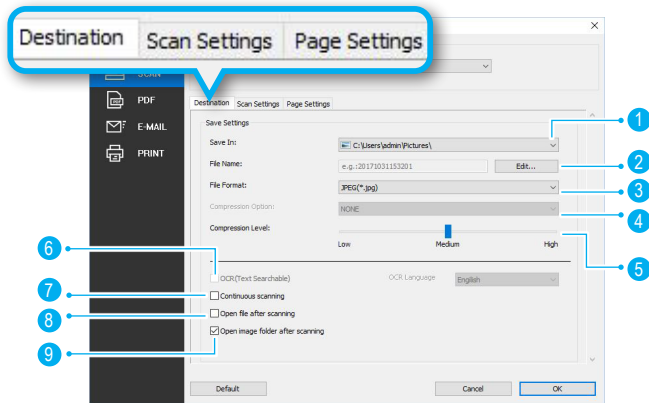

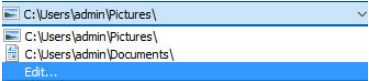
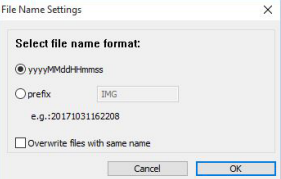
Name	Functions
1 Save In	Indicates the folder where image files are saved. Click Browse to specify a file folder to save the scanned image. 
2 File Name Settings	You can create a filename format for the scanned image with either one of this setting. <ul style="list-style-type: none">• yyyyMMddHHmmss: The filename is created in the "yyyyMMddHHmmss" format with 4-digit serial number at the end.• Prefix: The filename is created with a prefix specified in the File Name up to 20 characters. 
3 File Type	Select a file format to save scanned image. Choices: JPEG(*.jpg), TIFF(*.tif), TIFF Multi-page(*.tif), BMP (*.bmp), PDF(*.pdf), PDF Multi-page (*.pdf). NOTE: Single Page PDF and TIFF are used for splitting the multi-page originals into single files. NOTE: Multi-Page PDF and Multi-TIFF are used for combining multiple originals into one file.

Scanning Using Event Utility (Continued)

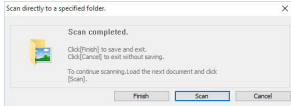
4	Compression Option	<p>When TIFF file is selected in the File Type, the Compression Option is enabled with following choices:</p> <ul style="list-style-type: none"> • None: No compression is used. • LZW: LZW is a compression method that results in no loss of data. The file size is closer to the actual size of the color data. • JPEG: JPEG is a lossy compression method that results in some data is lost. This method is best used to reduce the large file size.
5	Compression Level	<p>Use the slider to compress a file to reduce the total size in High, Medium, or Low. The higher the compression level, the lower the file size, and vice versa.</p>
6	OCR (Text Searchable)	<p>This setting is available with the Scan To PDF and OCR options. Ensure to select the correct language of the original text from the drop-down menu to perform text recognition.</p>
7	Continuous Scanning	<p>Check this option to trigger the continuous scanning dialog box after the current page is scanned, allowing you to continue scanning for more pages. See page 21.</p> 
8	Open file after scanning	<p>Check this function to open the scanned file automatically after scanning and saving completes.</p>
9	Open image folder after scanning	<p>Check this function to open the scanned image folder automatically after scanning and saving completes.</p>

Scan to Folder

This function allows to scan to a specified folder. When scanning completes, the scanned file will be saved directly into your folder on your computer. You can select drop-down menu and click **[Edit]** to specify a folder to save the scanned image.

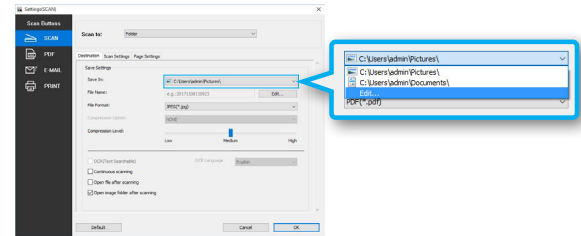

Scan to PDF

This function allows to scan and convert documents into PDF file format. When scanning completes, the scanned file will be saved in PDF format and opened in Acrobat Reader.

! NOTE:

- PDF (*.pdf) is used for splitting the multi-page originals into single page.
- PDF Multi-page (*.pdf) is used for combining multiple originals into one PDF file.

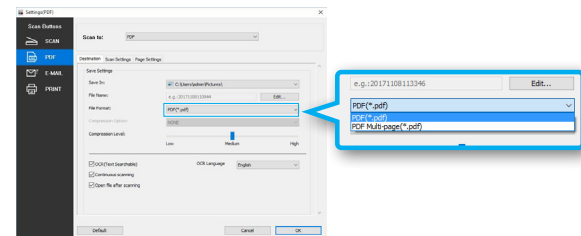

Scanning Using Event Utility (Continued)

Scan to E-Mail

This function allows direct scan to your E-mail with the files saved in the specified folder. When scanning completes, your default E-mail application will open and the scanned file will be attached to a blank email.

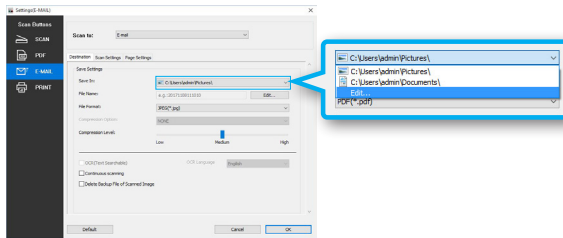

NOTE: Scan to E-Mail file format only support JPEG & PDF.

Scan to Print

This setting only available with the Scan To Print function. To select your printer to print the scanned file, click **[Property]** from the print selection.

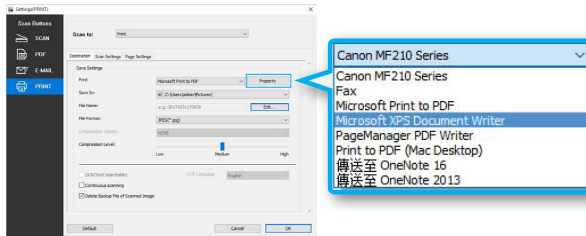

Scan to OCR

This function allows to scan and convert documents into an editable text file format according to your selected language in the OCR Language drop-down list.

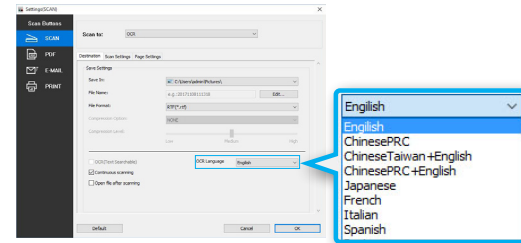

Scan to Application (Default: MSPaint)

This setting only available with the Scan To Application function. To add a new application, click **[Edit]** from the drop-down menu of Application and select **[Add]** to navigate to the .exe files in the Program folder, then click **[OK]** to add in the application list.

NOTE: Please make sure the application supports the File Type selected.

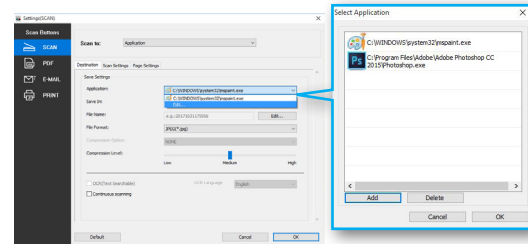

Scanning Using Page Event Utility (Continued)

The Scan Settings Tab

Click the "Scan Settings" tab to bring up the setting page for the Scan-to option selected. You can make change as following:

NOTE: After changing any settings and properties, always make sure to click **[OK]** at the bottom of the menu.

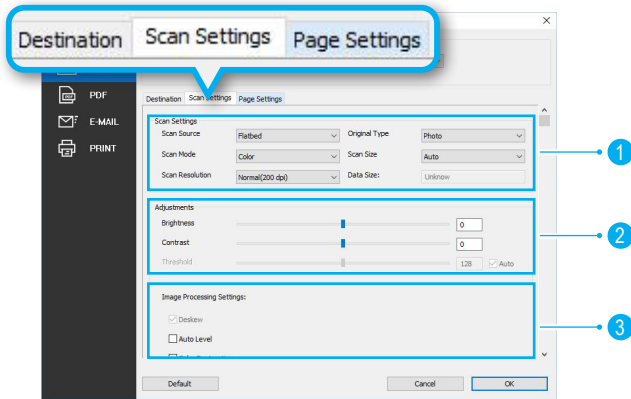

1. Scan Settings:

Scan Source, Scan Mode, Scan Resolution, Original Type, Scan Size, and Data Size Settings.

2. Adjustments:

Brightness, Contrast, and Thredhold Settings.





3. Image Processing Settings:

Auto Level, Color Restoration, De-screen, Unsharp Mask, Dust Removal, De-noise, Text Enhancement, Background Color Smoothing, Punch Holes Removal, and Edge-correction Settings.

Name	Functions
Scan Source	The Scan Source setting is fixed as Flatbed. You cannot change this setting. NOTE: The Scan Source may vary depending on your scanner type.
Scan Mode	Select a mode to scan your originals. Choices: "Color", "Gray", "B/W" 
Scan Resolution	Choices: "Normal(200dpi)", "Fine(300dpi)", "High(600dpi)" NOTE: If you want to scan in a higher resolution image, you can scan with ViiScan program or scan within an image application via TWAIN interface. * See page 10 for more details.
Originals Type	Select an option according to the type of originals to auto-adjust overall brightness and contrast for the scanned image. Photograph: Originals with mainly color pictures. Text Document & Linear: Originals with mainly text or line drawing. Magazine: Originals with both text and color pictures. NOTE: The Original Type setting will be disabled when Scan Mode selected to "B/W".
Scan Size	Select the output size of the image to be scanned with following choices: Auto, A3, A4, A6, B5, B6, Letter, Legal. NOTE: Select "Auto" to automatically detect the paper size and crop scanned image.
Data Size	The Data Size is calculated based on the Scan Size and Scan Resolution you select. The Data Size given here is only an estimate. The actual file size can be different than the estimate.

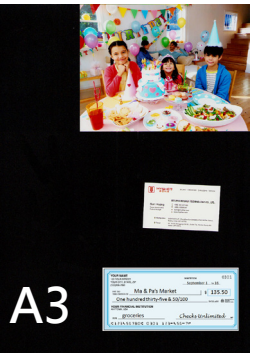
Scanning Using Event Utility (Continued)

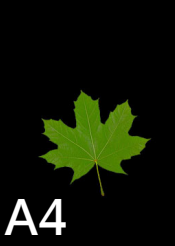
*. The following table gives function examples of the Scan Size settings.

Scan Size	A3 Scan and crop the original according to specified size.	Auto (Multiple Cropping) Crop and deskew scanned images automatically according to the originals size.
Output	 <p>A3</p>	
Scan Size	A4	Auto (Single Cropping)
Output	 <p>A4</p>	

! NOTE: Make sure there is a gap of at least 20 mm (0.8 in.) between the originals, when placing multiple originals on the scanner glass. Otherwise inaccurate-cropping may occur.

! NOTE:

1. The maximum area of this A3 scanner is 426 x 304mm, please place the originals within the area in order to make complete scan.

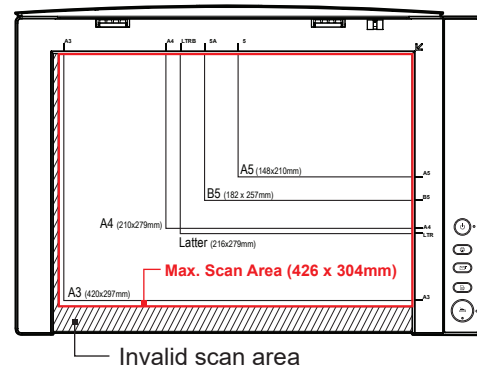

2. Please always place the original facing down on the Flatbed Glass, and then align the original at the position Arrow Mark. In order to make the correct scan and crop of selected size.

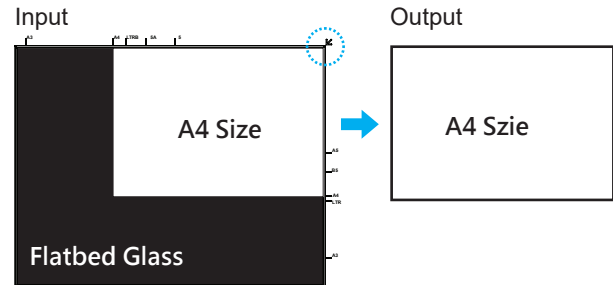

Scanning Using Event Utility (Continued)

Adjustments

The "Adjustments" includes Brightness, Contrast, and Threshold settings. You can make adjust as following examples:

NOTE: After adjusting slider, always make sure to click **[OK]** at the bottom of the menu.

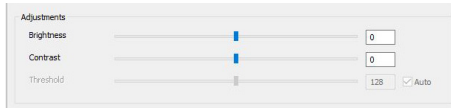

Brightness:

Use the slider to increase or decrease the value (-100 ~ 100) and to adjust the image brighter or darker.



Brightness -60



Brightness 0



Brightness 60

Contrast:

Use the slider to increase or decrease the value (-100 ~ 100) to adjust the contrast higher or lower. The bigger the value is to set towards 100, the more contrast is between lighter and darker areas.



Contrast -80



Contrast 0



Contrast 80

NOTE: Brightness and Contrast are enabled in "Color" and "Gray" mode only.

Threshold (B/W Only) :

This function is only available when scanning in B/W mode. You use the slider to adjust the Threshold value (-255 ~ 255) until you are satisfied with the result as following examples:
Manually



Example:

Checked "Auto" (Default)

It finds an adequate threshold value automatically to obtain a clear image and remove dark backgrounds from the image.



Example:

Manual threshold value to 110.

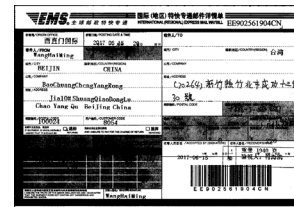



Example:



Manual threshold value to 170.

Scanning Using Event Utility (Continued)

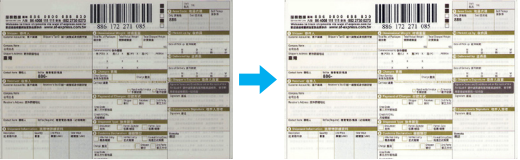
Image Processing Settings

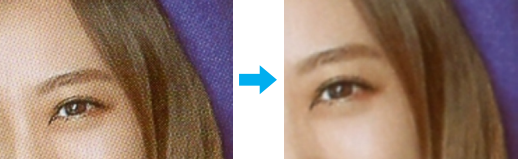
The following table gives examples of the image processing settings.

<p>Auto Level</p>	<p>The Auto Level allows automatically adjusts both the color and contrast of scanned image, based on the shadows, midtones, and highlights that it finds.</p> <p>Original Auto Level Applied</p> 
<p>Color Restoration</p>	<p>Color Restoration helps to restore the lost color in old pictures and makes them to their original colors.</p> 
<p>De-screen</p>	<p>De-screen helps to reduce moire patterns in magazines or other printed materials. After descreening, the image may appear blurry.</p> 

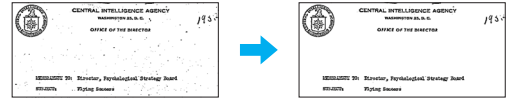
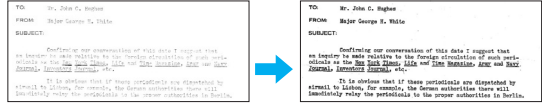
<p>Unsharp Mask</p>	<p>This function helps to emphasize edges in the image more clearly for an overall sharper image.</p> 
<p>Dust Removal</p>	<p>The dust removal function can remove dusts or scratch marks without affecting the image composition.</p> 
<p>De-noise</p>	<p>De-noise helps to remove small dots or specks appear in the background of scanned document.</p> <p>! NOTE: De-noise is enabled in "B/W" mode only.</p> 
<p>Text Enhancement</p>	<p>This function enhances the contrast between the texts and the background for readability.</p> <p>! NOTE: Text Enhancement is enabled in "B/W" mode only.</p> 

Scanning Using Event Utility (Continued)

Background Color Smoothing

The Background Color Smoothing function allows to smooth background color or remove it and make white.

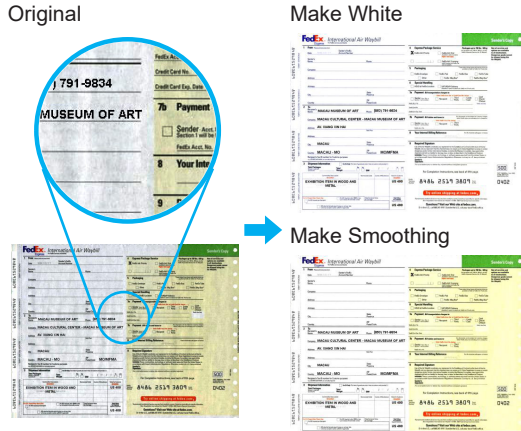

Punch Holes Removal

This function can remove the round-shaped punch holes around the edges of the documents. The punch holes around the edges are replaced with the color closest to the document.

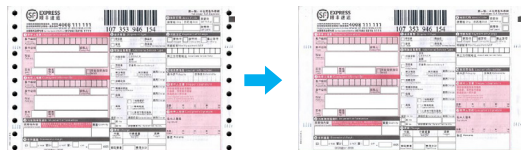

NOTE:

- Punch holes will not be removed if the documents are placed skewed and without cropping.
- The shape of punch holes that is not round can not be removed.
- Punch holes may not be removed if the holes overlap the text, lines or graphics.

Edge-correction Settings

This function fills the missing edges with a color which matches to the image. It also adds white or black edges onto the borders of the scanned documents.

Example 1: Automatically fill the color of missing edges.

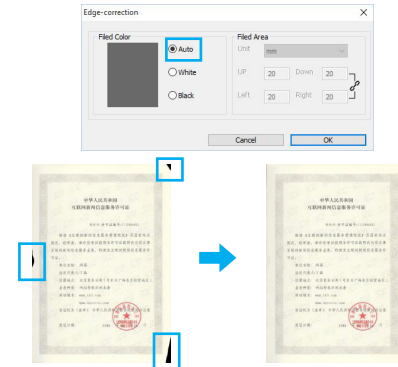

Example 2: Add white or black edge on the border of scanned document. You can also enter a value (1~20mm).

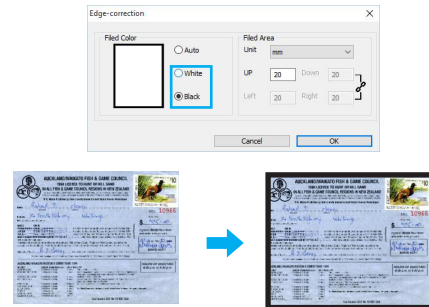



Scanning Using Event Utility (Continued)

The Page Settings Tab

The "Page Settings" includes Rotation, Mirror, and Invert settings. You can make changes as following examples:

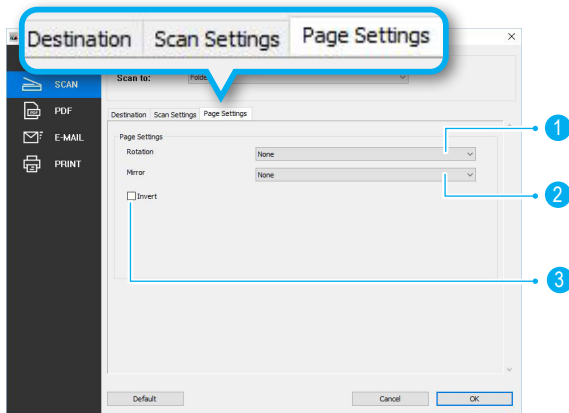
NOTE: After changing any settings, always make sure to click **[OK]** at the bottom of the menu.

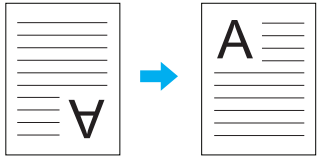
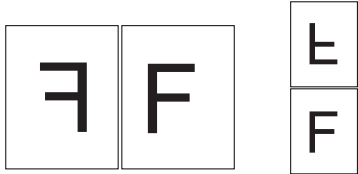

1	Rotation	<p>Select a rotation angle to rotate the image. Choices: "None", "90° CW", "90° CCW", "180°".</p> 
2	Mirror	<p>Select a mirror type for your document. Choices: "None", "Level", "Vertical"</p> 
3	Invert	<p>This function reverses the colors of the scanned image to the opposite colors.</p> 

Scanning Using Event Utility (Continued)

Reset to Default

To restore all the settings to default values of Event Utility, click **[Default]** at the bottom of the menu.

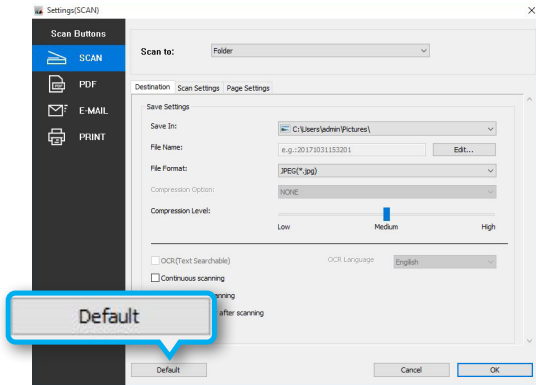

Exit Event Utility

To exit the Event Utility, right click on the Event Utility icon from the system tray then select "Exit".

! NOTE: You can also set the "Preferences" and turn On/Off "Tooltips" with this selection.

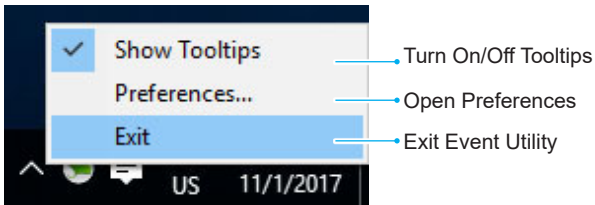

Preferences

You can make following changes within the preferences menu.

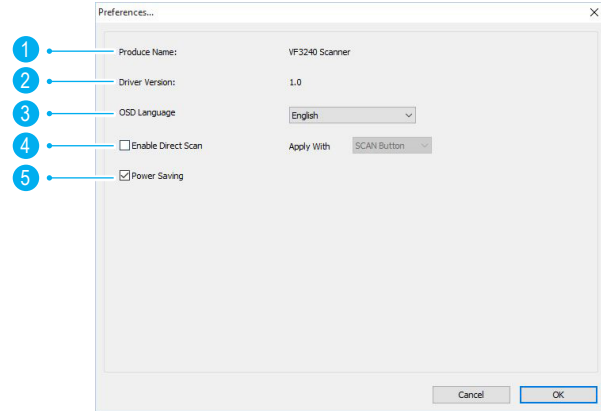

! NOTE: After changing any settings, always make sure click **[OK]** at the bottom of the menu.

1	Product Name: Display the the name of current connected scanner.
2	Driver Version: Display driver version.
3	OSD Language: Select and change on screen display language.
4	Enable Direct Scan: Enables Direct Scan with selected scan button settings. See page 36 for more details.
5	Power Saving: The scanner will auto turn off the power after no operation for 15 minutes when this function is checked.

Scanning Using Event Utility (Continued)

Enable Direct Scan

By detecting the cover sensor, the Direct Scan function enables the scanner to scan automatically when the scanner lid is closed as following steps:

1. Open Preferences menu and check **[Direct Scan]** then select one button to apply with its scan settings.

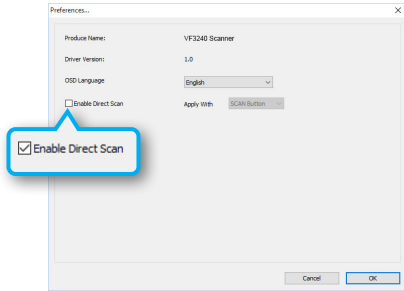

2. Open the scanner lid and place the original.

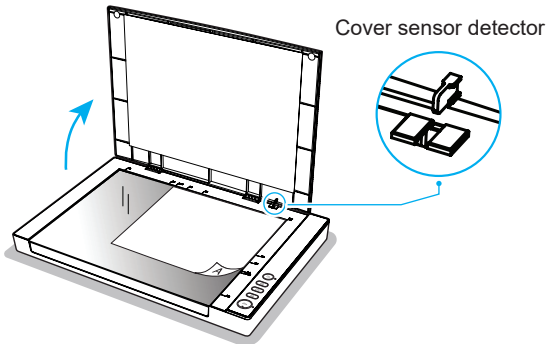

3. Close the scanner lid.

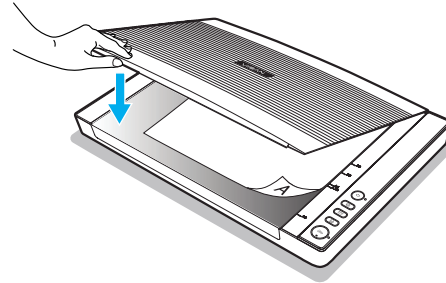

NOTE: Ensure the scanner lid is tightly closed, otherwise it may affect the Direct Scan function.

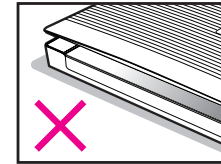
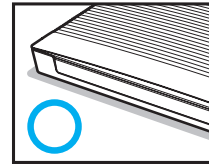

4. When the lid is closed, the scanner will perform a scan automatically. To continuous scanning, open the scanner lid and load the next document then close the lid again.

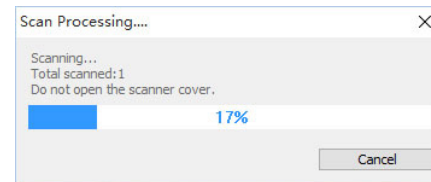

Maintenance

Cleaning the Flatbed Glass

1. Use a clean, lint-free cloth moistened with some isopropyl rubbing alcohol (95%) to clean the flatbed glass.

NOTE: Never spray the cleaner directly onto the Scanner.

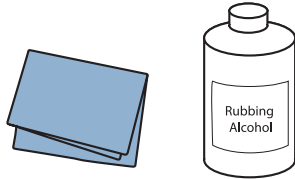

2. Hold the scanner lid at a 90-degree angle so it stands straight up.

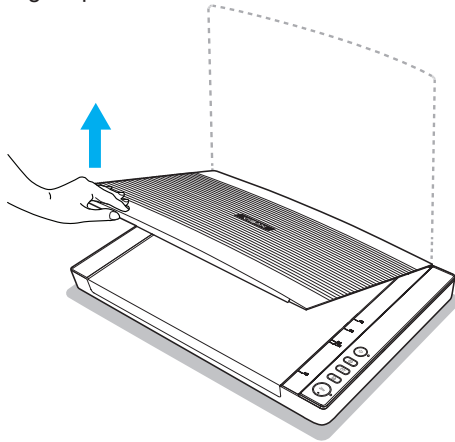

3. Wipe the entire surface of the flatbed glass.

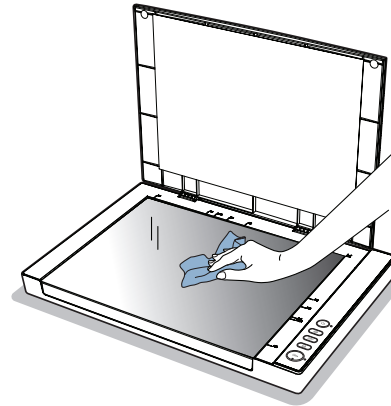

4. Close the scanner lid when cleaning is finished.

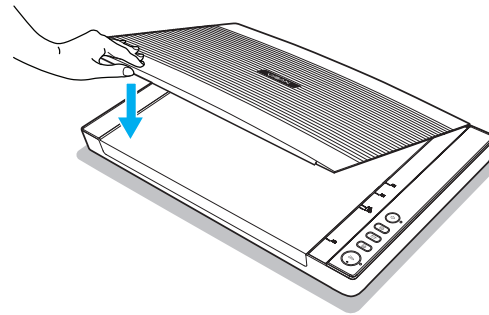

Specifications

Model	VF3240	VF3120
Scanner Type	A3 High Speed Flatbed Scanner	
Scan Sensor	Contact Image Sensor (CIS)	
Light Source	Three-color (RGB) LED	
Color Depth	Color: 48-bit input, 24-bit output Grayscale: 16-bit input, 8-bit output	
Optical Resolution	2400 dpi x 2400 dpi	1200 dpi x 1200 dpi
Scan Speed	4 Sec/page (200dpi, A3 Size)	8 Sec/page (200dpi, A3 Size)
Scan Area (Max.)	304 x 426 mm (11.98" x 16.8")	
Function Buttons	Scan / PDF / E-Mail / Print	
Output Format	BMP 、 PNG 、 JPEG 、 PDF 、 TIF 、 Multi-page PDF 、 TIF	
Interface	High Speed USB 2.0	
Protocol	TWAIN / WIA Compatible	
Power Requirements	12 VDC/2A, 24W (Input: 100~120VAC or 200~240VAC, 50~60Hz)	
Power Consumption	Scanning: 8.5W	
Power Saving	Auto power off after no operation for 15min	
Operation Temperature	10 °C - 35 °C (50 °F - 95 °F)	
Operation Humidity	110% to 85% RH	
Dimension (L x W x H)	565 x 394 x 61 mm	
Weight	Approx. 4.3 kgs (9.4 lbs)	
OS Compatibility	Windows 7, 8.1, 10, 11	

Troubleshooting

Scanner lights indicate an error:

Scanner displays red light.

- Make sure the scanner is connected to your computer properly.
- Make sure if the scanner is disconnected, turn off the scanner and turn it on again.
- Make sure scanner driver is installed and it appears in "Device Manager" correctly.

Scanner non-stop flashing green light.

- Long press power button until turn off power and turn it on again.
- Restart the scanning software.
- If this does not solve the problem, unplug and replug the power adapter then turn it on again.

Problems starting scanning:

Cannot scan using the button.

- Make sure the USB cable and power cable are securely connected to the scanner and the computer.
- Make sure "Event Utility" software is installed correctly.
- Make sure "Event Utility" is started in system tray correctly.
- Make sure scanner driver is installed and it appears in "Device Manager" correctly.
- Make sure the scanner is turned on.

Cannot scan using ViiScan.

- Make sure the USB cable and power cable are securely connected to the scanner and the computer.
- Make sure the scanner is turned on.
- Make sure scanner driver is installed and it appears in "Device Manager" correctly.
- Make sure if you are using "Event Utility" software, if yes please stop using it then start again ViiScan.

Cannot scan using TWAIN.

- If you are using TWAIN-compliant applications, make sure that the correct scanner is selected as the scanner.
- If you still can not scan with TWAIN-compliant applications, please reinstall again driver then try again.
- If you are using 32-bit Adobe Photoshop, make sure you have installed TWAIN Plug-in.
- TWAIN is not supported in Adobe Photoshop when it's run in 64-bit mode. If you need a scanning solution when you run Adobe Photoshop in 64-bit mode, use the WIA (Windows Image Acquisition) interface for your scanner.

Troubleshooting (Continued)

Scanned image problems:

Appear dirt and spots in scanned image.

- Clean the scanner glass. See page 37 for more details.
- Do not press with too much force on the original or the document cover. If you press with too much force, blurring, smudges, and spots may occur.

Appear moiré patterns in scanned image.

- If the original is a printed document, moiré patterns may appear in the scanned image.
- Go to the Image Processing Settings tab in ViiScan or Event Utility to check "Descreening" then scan again.

Scanning problems:

Cannot preview thumbnail in ViiScan.

- When placing multiple originals on the scanner glass, make sure there is a gap of at least 20 mm (0.8 inch) between the originals.
- Make sure the original is placed straight.

Cannot perform 1200/2400 dpi scanning.

- The supplied Event Utility software only provide scanning resolution of maximum 600dpi with the 32bit driver
- If you want to scan in a higher resolution image, you can scan within ViiScan program or via TWAIN-compliant applications by installing the 64-bit driver.

Cannot scan the correct area on the scanner glass.

- Make sure the original is placed correctly and align the position arrow mark.

Cannot save the file in the folder.

- Check if the folder specified in the Settings exists. If not, specify a different folder.
- Check if you have the available hard drive space in your computer to save the scanned files.

Cannot use the Scan to Email function.

- Make sure your email application has been installed and your email account is configured.
- If the file size of scanned file exceeds the attachment size limit set at your mail server, the files will be unable to send.

Cannot use the Scan to Print function.

- Make sure your printer driver is installed and the printer is connected to the computer.
- Make sure the printer is turned on.

Cannot use the Scan to Application function.

- Make sure the application used can support to open the file format you select in the Setting.

Troubleshooting (Continued)

Scanning speed is very slow.

- Scanning takes longer than usual when you scan at high resolution and large size.
- Set a lower resolution in the Settings to prioritize the scanning speed.
- When applying "Descreening" may slow down the scanning process.

The file size is too big.

- Compress the file into a smaller size using the File Compression slider.
- Set a lower resolution in the Settings.

Uninstalling and installing driver or applications:

Uninstalling your scanner driver and applications.

You may need to uninstall and then reinstall your scanner driver and applications to solve certain problems or if you upgrade your operating system.

1. Exit all running applications and disconnect the scanner from your computer.
2. Right click on start button and then select "Programs & Features". (e.g. Windows 10)
3. Select the application or driver that you want to uninstall.
4. Follow the instructions in the preceding procedure to uninstall an application or driver.

! **NOTE:** When reinstalling scanner driver, please replug scanner USB cable again and wait until scanner device is be configured successfully.

VIISAN

SMART IMAGING, CHANGES YOUR LIFE

www.viisan.com